

## IG Relay1 (Push Button Start)

### SECURITY AND LOCKS

## 38.IG Relay1 (Push Button Start)

### A: REMOVAL

#### CAUTION:

Before handling the airbag module, refer to “CAUTION” of “General Description” in “AIRBAG SYSTEM”. <Ref. to AB-9, CAUTION, General Description.>

1) Disconnect the ground cable from battery and wait for at least 60 seconds before starting work. <Ref. to NT-5, BATTERY, NOTE, Note.>

#### NOTE:

For models other than STI model, disconnect the ground terminal from battery sensor.

2) Remove the cover assembly - instrument panel LWR driver. <Ref. to EI-61, REMOVAL, Instrument Panel Lower Cover.>

3) Remove the knee airbag module. <Ref. to AB-35, REMOVAL, Knee Airbag Module.>

4) Release the lock and remove the fuse holder.

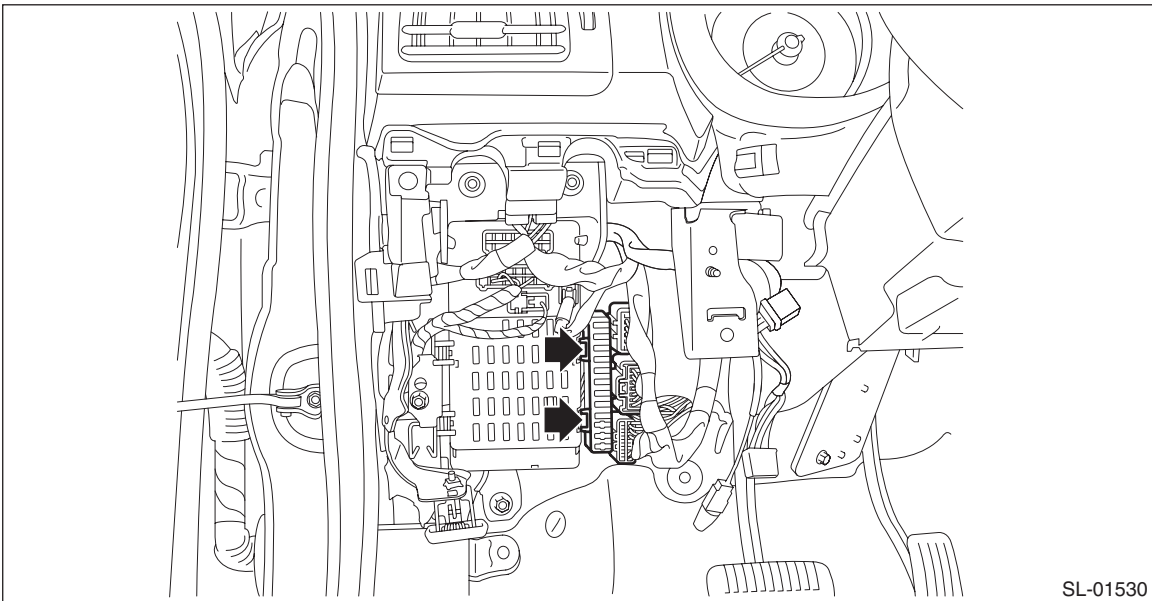

5) Remove the relay & fuse box.

(1) Disconnect the connector.

(2) Remove the bolts and nuts, and remove the relay & fuse box.

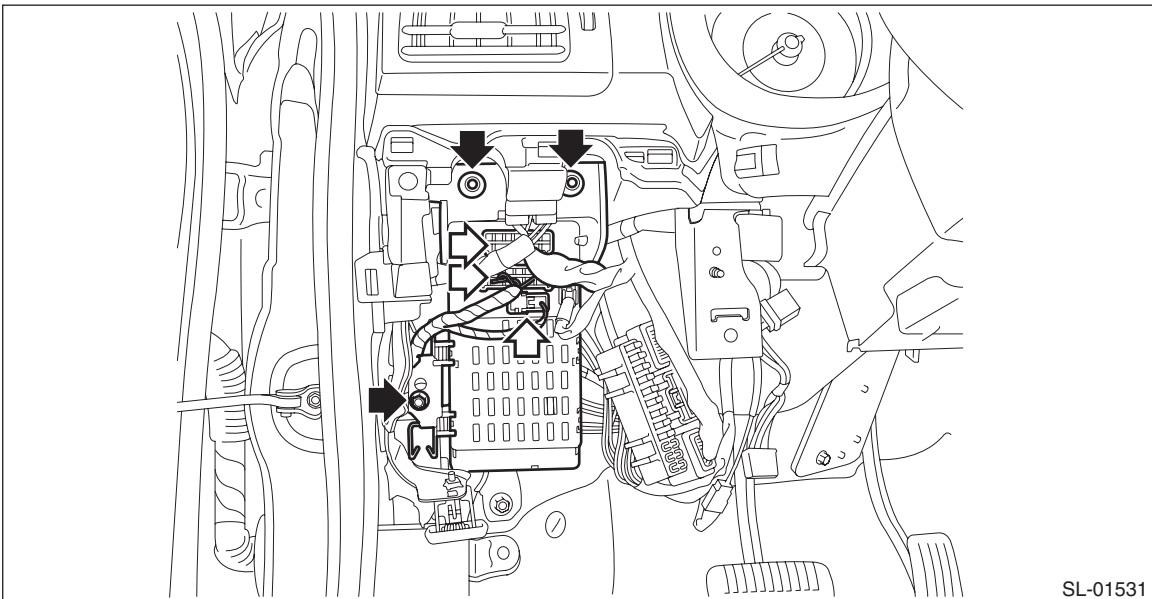

6) Remove IG relay 1 (push button start) (A) from the relay holder.

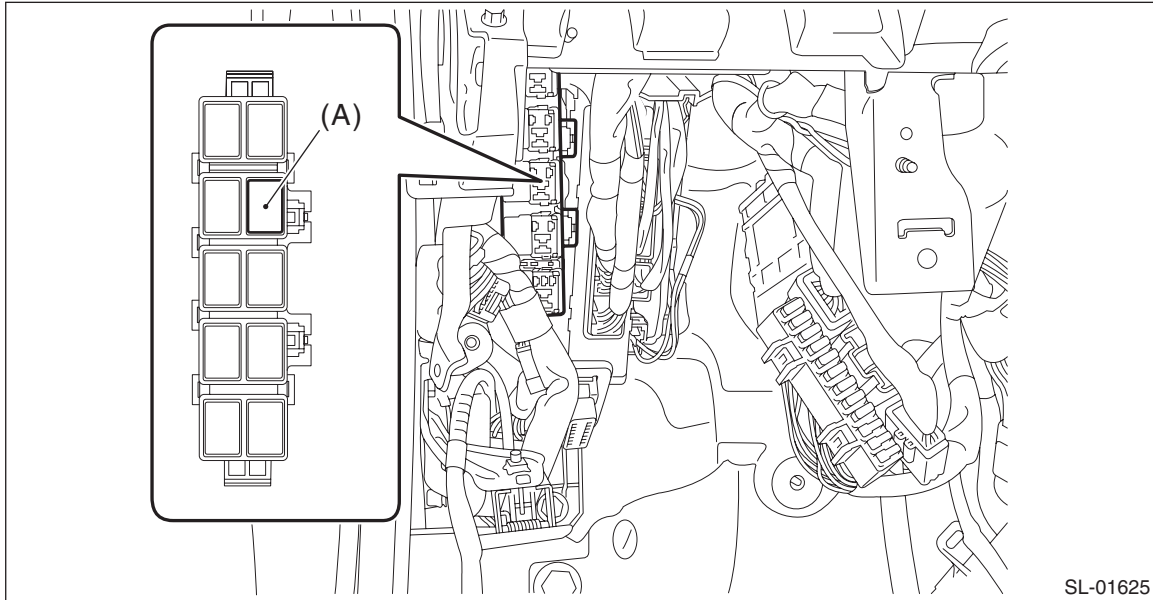

## B: INSTALLATION

### CAUTION:

Before handling the airbag module, refer to “CAUTION” of “General Description” in “AIRBAG SYSTEM”. <Ref. to AB-9, CAUTION, General Description.>

### NOTE:

Make sure that there are no differences from the contents of the current settings after installation. <Ref. to BC(diag)-15, LIST, Read Current Data.>

- 1) Install the IG relay 1 (push button start).
- 2) Install the relay & fuse box and fuse holder.

### Tightening torque:

**Relay & fuse box: 7.5 N·m (0.8 kgf-m, 5.5 ft-lb)**

- 3) Install the knee airbag module.

### Tightening torque:

**7.5 N·m (0.8 kgf-m, 5.5 ft-lb)**

- 4) Install the cover assembly - instrument panel LWR driver.
- 5) Connect the battery ground terminal. <Ref. to NT-5, BATTERY, NOTE, Note.>

### NOTE:

For models other than STI model, connect the ground terminal to battery sensor.

## C: INSPECTION

Refer to “CHECK RELAY” in “Relay and Fuse”. <Ref. to SL-9, CHECK RELAY, INSPECTION, Relay and Fuse.>